

158EZNF



Type N Female EZfit® for 1-5/8 in FXL-1873 and AVA7-50 cable

Product Classification

Product Type	Wireless and radiating connector
Product Brand	EZfit®
Ordering Note	CommScope® non-standard product

General Specifications

Body Style	Straight
Inner Contact Attachment Method	Captivated
Inner Contact Plating	Silver
Interface	N Female
Mounting Angle	Straight
Outer Contact Attachment Method	Clamp
Outer Contact Plating	Trimetal
Pressurizable	No

Dimensions

Length	2.76 in 70.104 mm
Diameter	2.48 in 62.992 mm
Nominal Size	1-5/8 in

Outline Drawing

158EZNF

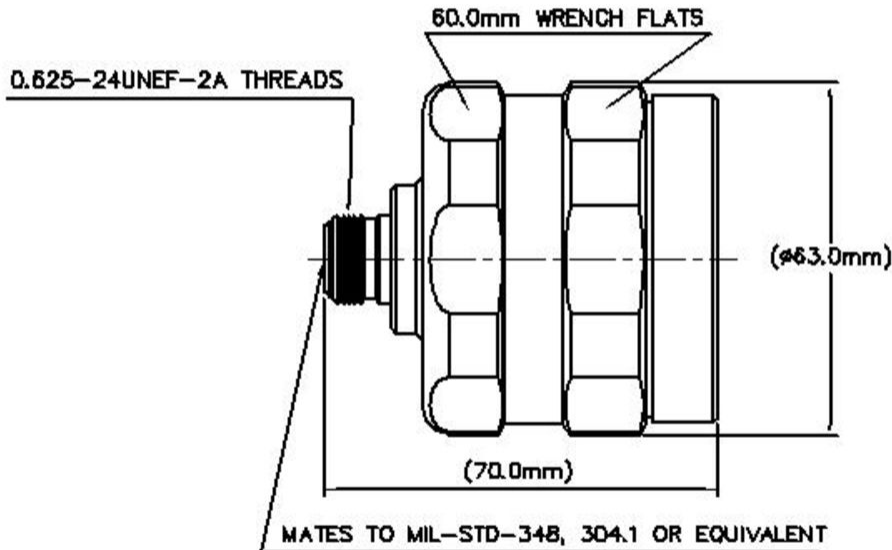

Electrical Specifications

3rd Order IMD at Frequency	-116 dBm @ 1800 MHz
3rd Order IMD Test Method	Two +43 dBm carriers
Insertion Loss, typical	0.05 dB
Attenuation, Ambient Temperature	20 °C 68 °F
Average Power at Frequency	0.6 kW @ 900 MHz
Cable Impedance	50 ohm
Connector Impedance	50 ohm
dc Test Voltage	2000 V
Inner Contact Resistance, maximum	2 mOhm
Insulation Resistance, minimum	5000 MOhm
Operating Frequency Band	0 – 2700 MHz

158EZNF

Outer Contact Resistance, maximum	0.3 mOhm
Peak Power, maximum	10 kW
RF Operating Voltage, maximum (vrms)	707 V
Shielding Effectiveness	-130 dB

VSWR/Return Loss

Frequency Band	VSWR	Return Loss (dB)
45–400 MHz	1.02	41.5
401–805 MHz	1.03	37.6
806–960 MHz	1.03	36.9
961–1709 MHz	1.03	36.61
1710–2170 MHz	1.04	34.16
2170–2399 MHz	1.05	32.26
2400–2700 MHz	1.06	30.8

Mechanical Specifications

Attachment Durability	25 cycles
Connector Retention Tensile Force	500 lbf 2,224.11 N
Connector Retention Torque	120 in lb 13.558 N-m
Insertion Force	15 lbf 66.723 N
Insertion Force Method	MIL-C-39012C-3.12, 4.6.9
Interface Durability	500 cycles
Interface Durability Method	IEC 61169-16:9.5
Mechanical Shock Test Method	MIL-STD-202F, Method 213B, Test Condition C

Environmental Specifications

Operating Temperature	-40 °C to +85 °C (-40 °F to +185 °F)
Storage Temperature	-55 °C to +85 °C (-67 °F to +185 °F)
Average Power, Ambient Temperature	40 °C 104 °F
Corrosion Test Method	MIL-STD-1344A, Method 1001.1, Test Condition A
Immersion Depth	1 m
Immersion Test Mating	Mated
Immersion Test Method	IEC 60529:2001, IP68
Moisture Resistance Test Method	MIL-STD-202F, Method 106F

158EZNF

Thermal Shock Test Method	MIL-STD-202F, Method 107G, Test Condition A-1, Low Temperature -55 °C
Vibration Test Method	IEC 60068-2-6
Water Jetting Test Mating	Mated
Water Jetting Test Method	IEC 60529:2001, IP66

Packaging and Weights

Weight, net 536.9 g | 1.184 lb

Regulatory Compliance/Certifications

Agency	Classification
ISO 9001:2015	Designed, manufactured and/or distributed under this quality management system
REACH-SVHC	Compliant as per SVHC revision on www.commscope.com/ProductCompliance
ROHS	Compliant



* Footnotes

Immersion Depth	Immersion at specified depth for 24 hours
Insertion Loss, typical	$0.05\sqrt{\text{freq}}$ (GHz) (not applicable for elliptical waveguide)